

Operator's Manual



RK-10 *DiaKat*®

Crack chaser

Read the operator's manual carefully and understand the contents before you use this equipment. Always use the machine in accordance with all the instructions contained in this manual, in order to ensure safe and efficient operation as well as longevity of the machine.

The manufacturer can not be held responsible for any damages or injury arising from the use of the machine not in accordance with the instructions contained in this manual.

CONTENTS

1. SAFETY INSTRUCTIONS.....	2
1.1. General safety instructions	2
1.1.1. Qualification requirements	2
1.1.2. Duties of the entrepreneur:	2
1.1.3. Duties of the operator:.....	2
1.1.4. Using the machine	3
1.1.5. Checkups, maintenance, service and repair.....	3
1.2. Transporting the machine.....	3
1.3. Prohibited activities.....	4
1.4. Hygienic instructions.....	4
1.5. Ecological instructions	4
1.6. Liquidating the machine at the end of its useful lifetime	4
1.7. Safety instruction for work with RK-10 Crack Chaser	5
2. TECHNICAL DATA AND DESCRIPTION OF THE MACHINE	5
2.1. Description of the machine.....	5
2.2. Technical specifications	5
2.3. Primary operative parts of the machine.....	6
3. BEFORE STARTING	6
3.1. Visual check up of the machine state	6
4. WORKING WITH THE MACHINE.....	7
4.1. Mounting of the tool.....	7
4.2. Working with the machine	7
4.3. Termination of work.....	7
5. MAINTENANCE	8
5.1. Cleaning of the machine.....	8
5.2. Checking screw joints	8
5.3. Engine maintenance	8
5.4. Tool maintenance	8
5.5. Inspection of tautness of V belts	8

1. SAFETY INSTRUCTIONS

1.1. General safety instructions

1.1.1. Qualification requirements

Persons operating this machine must fulfil the following requirements:

1. The machine may be operated independently only by workers who are:
 - older than 18- teen years (or as the law in the country of use prescribes)
 - physically and mentally competent
 - trained, who proved their ability to operate the machine safely

2. All workers who will operate this machine must make themselves familiar with all the instructions contained in this manual and must adhere to them.

3. The operator must make himself familiar with all the safety instructions pertinent for use of this machine (including those specific to the country of use) and must adhere to them. The familiarisation must be documented and signed by the operator.

1.1.2. Duties of the entrepreneur:

Entrepreneur is a physical or legal entity who undertakes the work with this machine. The entrepreneur is the guarantor of the safe use of the machine.

The entrepreneur must:

- appoint the operator and provide his training
- insure safe conditions for the use of the machine by the operator
- provide regular checks and maintenance of the machine
- ensure adherence to legal requirements for the safety of the work
- regularly check observance of safety regulations
 - regularly check if the operator is using the machine in conformity with the operator's manual

1.1.3. Duties of the operator:

Operator is a person which actually uses the machine to do the work for which the machine is designed. The operator must fulfil the requirements as set in 1.1.1.

Operator must:

- thoroughly familiarise himself with the Operator's manual and all safety instruction required for the work
- comply with all instructions and requirements set in this manual
- comply with all safety regulations set for work with machinery
- acquaint himself with the work environment including safety instructions
- pay full attention to operating the machine whilst working
- demand regular checks and maintenance of the machine as prescribed by this manual
- demand from his employer securing of conditions conducive to upkeep of safety regulations
 - secure the machine against accidental movement and out of reach of unauthorised persons when not working

1.1.4. Using the machine

When using the machine the operator must comply with the following instructions:

1. Check the machine before use.
2. Before commencing work check if it is safe to start the machine with out endangering the operator or other persons.
3. Use prescribed personal safety aids while working. (Helmet, earmuffs, safety shoes, goggles, respirator, gloves...).
4. Do not start the machine in enclosed area.
5. While working monitor the machine for unusual sounds or smoke which may indicate defect. When defect is indicated immediately stop the machine and call for expert repair.
6. Always switch off the engine when refuelling. Take care that the fuel does not come into contact with hot parts of the engine. Wipe out immediately any spillage.
7. **!ATTENTION!** It is important to immediately repair or change improperly sealed or leaky fuel tank and lines. Improperly sealed or leaky fuel tank and lines may cause an explosion.
8. It is necessary to provide an adequate supply of fresh air for the operator, when using the machine in enclosed areas (tunnels etc.).
9. When finish working, switch off the engine and move the machine the secure place and insure against unauthorized use.

1.1.5. Checkups, maintenance, service and repair

- regularly check the technical state of the machine.
- if fault or damage is discovered ensure expert repair.
- repair or service may be carried out only by qualified personnel from a manufacturer's service organisation.
- it is prohibited to carry repairs or service at places where the safety of work is not ensured and can be affected by outside impingement, such as falling objects, collision with other machinery etc.
- changes and alteration to the machine can be carried out only with the explicit agreement of the manufacturer!

1.2. Transporting the machine

1. Always transport the machine in a secured position on its transport wheels.
2. When transporting secure the machine against overturning, moving or falling off.
3. Never transport the machine with the engine running!

1.3. Prohibited activities

When using the machine it is forbidden:

1. Using the machine for work other than for which is designed.
2. Operating the machine in other manners than those described in this manual.
3. Using the machine under influence of alcohol, narcotics or drugs and medicaments.
4. Using the machine whilst its running may endanger the safety of persons, property or traffic.
5. Bring in to operation and work with the machine if any of the safety features are dismantled or damaged. (Tool cover, rubber cover etc.)
6. Leave running or unsecured machine without safeguarding it against unauthorised use.
7. Use the machine if fuel, oil or any operating liquid is leaking.
8. Cleaning the machine while it is running.
9. Cleaning the machine with high pressure water.
10. To smoke or manipulate with naked flame while checking fuel or refuelling.

1.4. Hygienic instructions

Fuel, lubricants and operating media of various components of the machine (engine, gearbox etc.) are substances hazardous to environment. At the end of its useful lifetime they become hazardous waste. It is necessary to store, dispose or liquidate them in accordance with appropriate rules or legislation pertinent to the country where the machine is used.

!ATTENTION! Observe the rules and regulations pertinent to the country of use concerning regular breaks.

The declared level of acoustic pressure A at the operators station $L_{pAd} = (105,4 \pm 3)$ dB (measured accordingly to CSN EN ISO 11201, working conditions accordingly to ČCN EN 13862+A1).

Guaranteed level of acoustic power A $L_{WA,G} = 108$ dB (measured accordingly to NV No.9/2002 Sb., attachment No.3, part B a CSN ISO 3744).

Given acceleration of vibrations transmitted to operators arms a_{hvd} is smaller than $2,5 \text{ m.s}^{-2}$ (measured accordingly CSN EN ISO 20643, working conditions ordained accordingly to CSN EN 13862 +A1, attachment F, when loaded).

1.5. Ecological instructions

Fuel, lubricants and operating media of various components of the machine (engine, gearbox etc.) are substances hazardous to environment. At the end of its useful lifetime they become hazardous waste. It is necessary to store, dispose or liquidate them in accordance with appropriate rules or legislation pertinent to the country where the machine is used.

1.6. Liquidating the machine at the end of its useful lifetime

When liquidating or disposing of the machine it is absolutely necessary to adhere to all rules or legislation pertinent to the country where the machine have been is used.

The manufacturer can not be held responsible for damages to health or environment in cases where all the above mentioned principles where not adhered to.

1.7. Safety instruction for work with RK-10 Crack Chaser

When working with the machine the following instructions must be complied with:

1. It is prohibited to work with the machine with out the tool cover.
2. Person except the operator is permitted within the danger perimeter of the machine.
- 3 Start the machine only in the safety, non working mode. Ensure that the tool is a safe distance off the ground.
4. Always change the tool with the machine in secure position with the engine switched off.
5. Observe all general rules of safe work.

2. TECHNICAL DATA AND DESCRIPTION OF THE MACHINE**2.1. Description of the machine**

The RK 10 Crack chaser is designed to cut expansion joints and wild cracks.

RK 10 Crack chaser (further only chaser) consist of an undercarriage , driving head consisting of bearings, drive shaft, pulley, two flanges and M20 fastening nut. On the undercarriage is mounted an engine with pulley, two V belts and a cover. The engine mounting bolts are in slots in the undercarriage to facilitate belts tightening. The swivelling tool cover with a front traversing wheel is also mounted on to the undercarriage. The position of the tool is secured by a mechanical brace on a steel rod with threaded control close to the handlebars or hydraulic brace operated by a button. The handlebars are mounted on four flexible bocks.

2.2. Technical specifications

Machine weight	kg	65	76	82	75
Dimensions	mm	790 x 950 x 950			
Power unit		HONDA			SIEMENS
Engine type		GX 160	GX 270	GX 390	3f / 380V
Nominal power	HP/kW	5,5 / 4,1	9,0 / 6,7	13,0 / 9,6	5,4 / 4,0
Engine rpm	ot/min	3600			2905
Blade diameter	mm	180			
Spindle rpm	ot/min	4560			3680
Peripheral speed of tool	m/s	43			35
Max. depth of cut	mm	30			

2.3. Primary operative parts of the machine

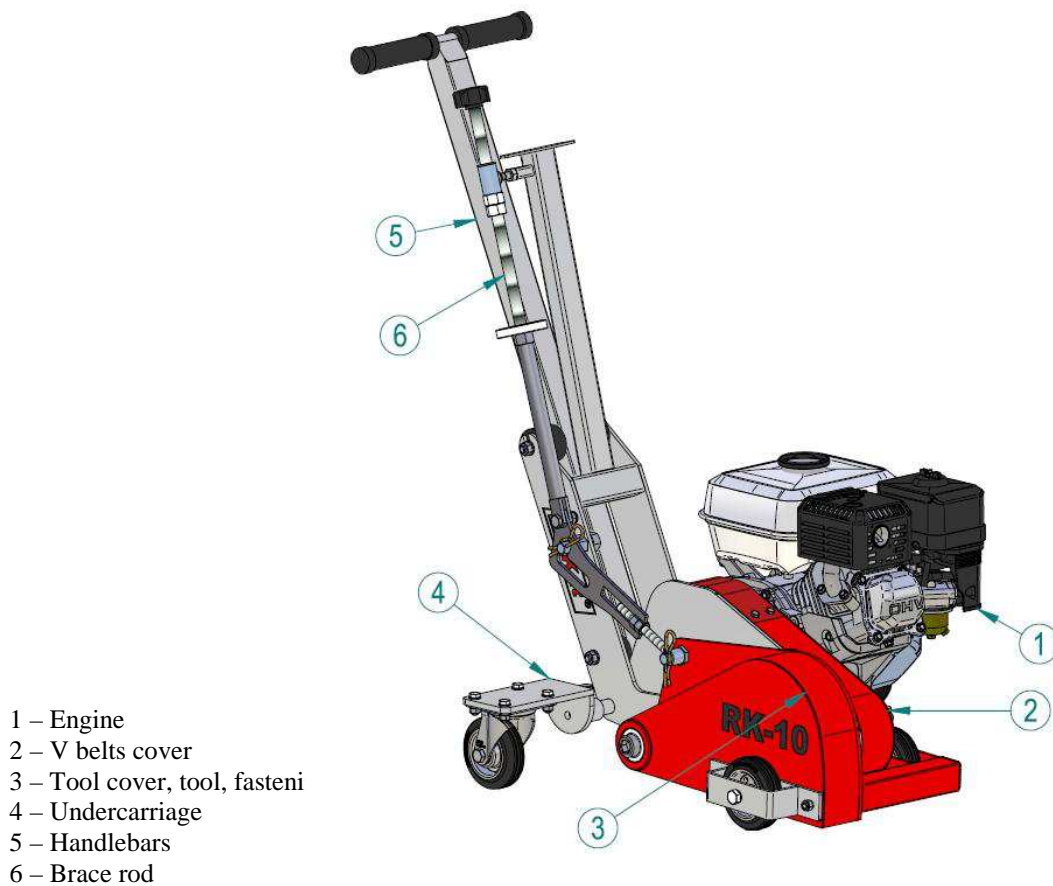

Pic. 1 Description of operative parts

3. BEFORE STARTING

3.1.

3.2. Visual check up of the machine state

Regularly (before commencing work) check:

- all covers and safety features (overall state of machine)
- inside of the cover (check for fouling)
- all screwed joints
- sealing of fuel and lubrication system
- cleanness of air filter (see engine manual)
- oil level (see engine manual)
- fuel level (HONDA– **Natural 95**)
- state of tool's wear

Remedy all faults or fouling before commencing work!

4. WORKING WITH THE MACHINE

4.1. Mounting of the tool

!Attention! Before any manipulation check if the engine is switched off. When changing the tool you can tilt the machine on its handlebars to 45°.

1. Loosen the M 20 nut on the tool spindle and take off the outside flange.
2. Mount the tuck point or crack chaser with bore 25,4 mm on the spindle and remount the flange. Check the indicated sense of rotation.
4. Retighten the M20 nut.

4.2. Working with the machine

!ATTENTION! Never start the engine if the tool is touching the ground.

1. Pull and depress the handlebars towards you and lift the machine to upper transporting position, the brace will click in a secure the position. Make sure that the tool is not touching the ground, if yeas, adjust with the threaded rod.
2. Bring the machine above the intended cut.
3. Start the engine (see the engine manual), set the throttle to maximum revs.
4. Pull the handlebars and the rod (it will release the mechanical brace) and slowly lower the machine. Set depth of cut by the knob on the rod. Lock the rod in the set depth by the plastic locking ring.
5. Move the machine slowly and steadily forward.
6. When the cut is finished repeat step 1 and set idling revs, move the machine to next cut, slightly tilt the machine and pull the rod, lower the machine in the cut, it will cut to the depth preset in step 4.

4.3. Termination of work

1. Stop the engine and shut off the fuel, implement all steps described in the engine manual.
2. Clean the machine including the inside of the tool cover and check the wear of the tool.
3. Store the chaser in safe and dry place.

5. MAINTENANCE

The basic steps of preventive maintenance described in this manual can be carried out by the operator appointed by the entrepreneur. We recommend that all repairs and adjustments beyond the scope of this manual are carried out by authorised service centre.

!ATTENTION! In the guarantee period it is prohibited to interfere with the engine and power transmitting components in any manner whatsoever!

!ATTENTION ! It is prohibited to change the rev setting in any way!

5.1. Cleaning of the machine

Regular cleaning prolong the life of the machine its components and tools. After finishing work clean the machine from dust and dirt by wet cloth or air before storing. Never use pressurised water for cleaning.

5.2. Checking screw joints

Check the tightness of screw joints before every start of the machine. Regularly check the tightness of tool fastening nut.

5.3. Engine maintenance

See engine manual.

Take extra care about cleanness of the engine and its cooling fins. Dirty engine=short life. Clean the air filter regularly even during single shift if necessary. If the chaser is not used in two month, change the oil.

5.4. Tool maintenance

Regularly check the wear and soiling of tools. If the diamond segments are almost worn off, change the tool.

5.5. Inspection of tautness of V belts

Regularly check the tautness of the V belts. The deflection of the V belt under the pressure of an index finger should be approximately 20 mm.

If the v belts needed to be drawn tauter proceed as follows:

Always carry this operation with cold, switched off engine.

1. Loosen the four bolts by which the engine is mounted on the undercarriage.
2. Push the engine backwards.
(You can check the tautness of the belts trough the hole in the V belt cover.)
3. Retighten the bolts.